

Unit: mm

Diaphragm Valve Weld End

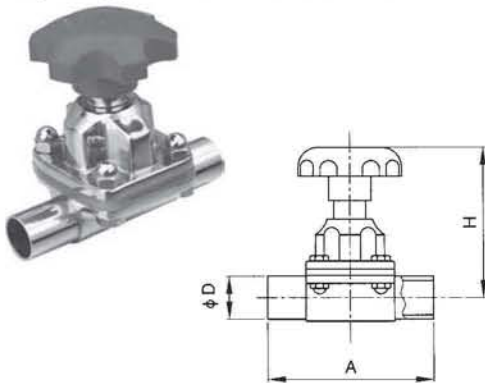

DIN

Size	A	D	H
DN15	115.0	18.0	88/99
DN25	125.0	28.0	110/123
DN32	140.0	34.0	129/138
DN40	150.0	40.0	139/159
DN50	180.0	52.0	159/186

SMS

Size	A	D	H
25	125.0	25.4	110/123
32	140.0	31.8	129/138
38	150.0	38.1	139/159
51	180.0	50.8	159/186

ISO/IDF

Size	A	D	H
3/4"	100.0	19.0	88/99
1"	125.0	25.4	110/123
1 1/4"	140.0	31.8	129/138
1 1/2"	150.0	38.1	139/159
2"	180.0	50.8	159/186

3A

Size	A	D	H
1/2"	100.0	12.7	88/99
3/4"	100.0	19.0	88/99
1"	125.0	25.4	110/123
1 1/4"	140.0	31.8	129/138
1 1/2"	150.0	38.1	139/159
2"	180.0	50.8	159/186

Diaphragm Valve Thread End

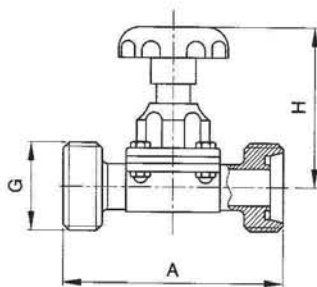

DIN

Size	A	G	H
DN20	153.0	RD44X1/6	91/102
DN25	165.0	RD52X1/6	110/123
DN32	180.0	RD58X1/6	129/138
DN40	190.0	RD65X1/6	139/159
DN50	222.0	RD78X1/6	159/186

SMS

Size	A	G	H
25	161.0	RD44X1/6	110/123
32	176.0	RD48X1/6	129/138
38	190.0	RD60X1/6	139/159
51	220.0	RD70X1/6	159/186

ISO/IDF

Size	A	G	H
1"	168.0	37.0X8TACME	110/123
1 1/2"	193.0	50.6X8TACME	139/159
2"	223.0	64.2X8TACME	159/186

3A

Size	A	G	H
1"	179.0	45.7X1/8TWHIT	110/123
1 1/2"	204.0	58.4X1/8TWHIT	139/159
2"	234.0	72.7X1/6TWHIT	159/186

Diaphragm Valve Clamp End

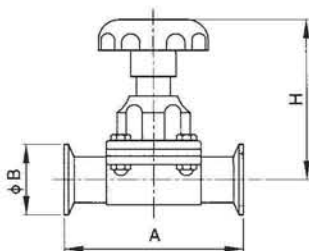

DIN

Size	A	B	H
DN15	115.0	34.0	88/99
DN20	129.0	34.0	91/102
DN25	129.0	50.5	110/123
DN32	147.0	50.5	129/138
DN40	159.0	50.5	139/159
DN50	190.0	64.0	159/186

SMS

Size	A	B	H
25	129.0	50.5	110/123
32	147.0	50.5	129/138
38	159.0	50.5	139/159
51	190.0	64.0	159/186

ISO/IDF

Size	A	B	H
3/4"	100.0	25.4	88/99
1"	129.0	50.5	110/123
1 1/4"	147.0	50.5	129/138
1 1/2"	159.0	50.5	139/159
2"	190.0	64.0	159/186

3A

Size	A	B	H
1/2"	100.0	25.4	88/99
3/4"	100.0	25.4	91/102
1"	129.0	50.5	110/123
1 1/2"	159.0	50.5	139/159
2"	190.0	64.0	159/186

3A Pneumatic Diaphragm Valve

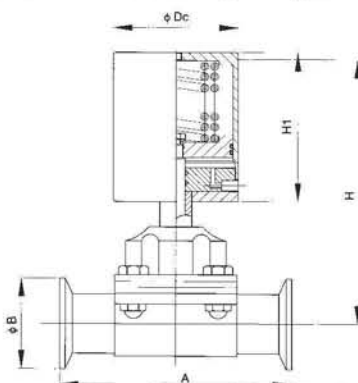

Size	A	B	H	H1	Dc
1/2"	100.0	25.4	156.3	98.0	63.5
3/4"	100.0	25.4	160.0	98.0	63.5
1"	129.0	50.5	176.0	98.0	63.5
1 1/2"	159.0	50.5	207.0	120.0	85.0
2"	190.0	64.0	213.4	120.0	85.0